

Steckerbelegung / Pin Assignment

CMx-58 CANopen 2x M12 (radial) + ERR-LED

Allgemeine Hinweise:

Wenn das Mess-System die letzte Station im CANopen-Segment ist, muss der DIP-Schalter **SW2** für den CAN-Bus-Terminator (Zuschaltung des Abschlusswiderstandes) eingeschaltet werden (SW2=ON). Sonst muss er ausgeschaltet sein (SW2=OFF). Bei der Zuschaltung des Abschlusswiderstandes wird der nachfolgende Bus (CANopen_OUT) abgeschaltet, nachfolgende Slaves werden vom Bus getrennt.

Für den Betrieb sind nur paarweise verdrehte und geschirmte Bus- bzw. Anschlusskabel zu verwenden. Der Schirm ist jeweils auf die Kabelverschraubung des Gegensteckers aufzulegen.

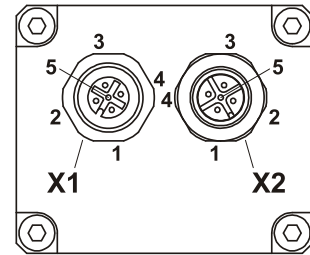

X1	CANopen_OUT, M12-Buchse (M12x1-5 pol. A-kodiert)
Pin 1	CAN_Shield
Pin 2	US-Versorgung, 11-27 V DC
Pin 3	0V-Versorgung
Pin 4	CAN_H
Pin 5	CAN_L

X2	CANopen_IN, M12-Stecker (M12x1-5 pol. A-kodiert)
Pin 1	CAN_Shield
Pin 2	US-Versorgung, 11-27 V DC
Pin 3	0V-Versorgung
Pin 4	CAN_H
Pin 5	CAN_L

SW1 Identifier (ID), Encoderadressierung						
DIP-6 = ID 2 ⁵	DIP-5 = ID 2 ⁴	DIP-4 = ID 2 ³	DIP-3 = ID 2 ²	DIP-2 = ID 2 ¹	DIP-1 = ID 2 ⁰	Adresse = ID
off	off	off	off	off	off	1
off	off	off	off	off	on	2
off	off	off	off	on	off	3
.
on	on	on	on	on	off	63
on	on	on	on	on	on	64

SW3 Baudrate			
DIP-2	DIP-1	Baudrate	Leitungslänge [m]
off	off	20 kBaud	bis 2500
off	on	125 kBaud	bis 500
on	off	500 kBaud	bis 100
on	on	1 MBaud	bis 25

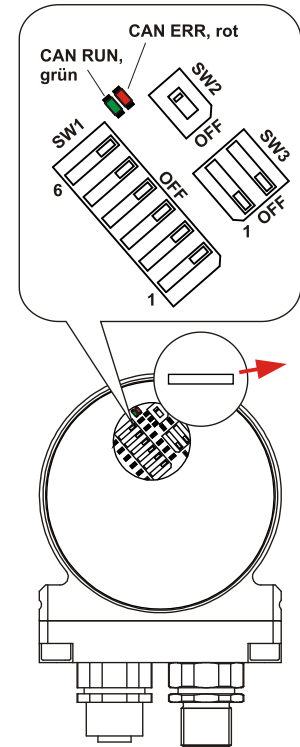

Bus-Statusanzeige:

LED	Beschreibung
ON	permanent AN
OFF	permanent AUS
Blinking	Gleiche AN- und AUS-Zeit mit einer Frequenz von 2,5 Hz: AN = 200 ms, AUS = 200 ms
Single flash	Einmaliges kurzes Aufblinken, 200 ms AN, gefolgt von einer langen AUS-ZEIT, 1000 ms
Double flash	Zweimaliges kurzes Aufblinken, jeweils 200 ms AN und AUS
Triple flash	Dreimaliges kurzes Aufblinken, jeweils 200 ms AN und AUS
Flickering	Gleiche AN- und AUS-Zeit mit einer Frequenz von 10 Hz: AN = 50 ms, AUS = 50 ms
Flicker flash	alle 5000 ms für 500 ms Flickering (überlagert die oben aufgeführten Blinkzustände)

grün	CAN RUN_LED
ON	Gerät befindet sich im OPERATIONAL Zustand
OFF	Versorgung fehlt, Hardwarefehler
Blinking	Gerät befindet sich im PRE-OPERATIONAL Zustand
Single flash	Gerät befindet sich im STOPPED Zustand
Triple flash	Boot-Loader aktiv (Software Download findet statt)
Flickering	LSS-Configuration aktiv
Flicker flash	Node-ID und Baudrate über LSS aktiv

rot	CAN ERR_LED
ON	keine Gegenstelle erkannt (Bus OFF)
OFF	kein Fehler
Single flash	zu viele Fehler im CAN-Controller
Double flash	Node Guarding- oder Heartbeat-Fehler
Flickering	Geräte Hardwarefehler (z.B.: Sprung- oder EEPROM-Fehler)

Steckerbelegung / Pin Assignment

CMx-58 CANopen 2x M12 (radial) + ERR-LED

General note:

If the measuring system is the last station in the CANopen-segment, the DIP switch **SW2** for the CAN-bus terminator (switching-on of the terminal resistance) must be switched on (SW2=ON). Otherwise the terminator must be switched off (SW2=OFF). If the terminal resistance is switched on the following bus (CANopen_OUT) is switched off and the slaves are separated from the bus.

For the operation shielded twisted-pair bus- or connection-cables must be used. The shield has to be connected to the cable screw gland of the mating connector.

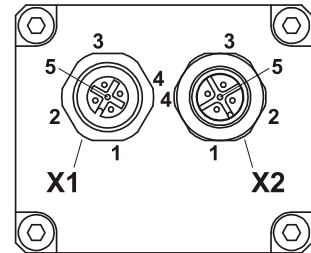

X1	CANopen_OUT, M12 female (M12x1-5 pol. A-coded)
Pin 1	CAN_Shield
Pin 2	US-supply voltage, 11-27 V DC
Pin 3	0V-supply voltage
Pin 4	CAN_H
Pin 5	CAN_L

X2	CANopen_IN, M12 male (M12x1-5 pol. A-coded)
Pin 1	CAN_Shield
Pin 2	US-supply voltage, 11-27 V DC
Pin 3	0V-supply voltage
Pin 4	CAN_H
Pin 5	CAN_L

SW1 Identifier (ID), Encoder addressing						
DIP-6 = ID 2 ⁵	DIP-5 = ID 2 ⁴	DIP-4 = ID 2 ³	DIP-3 = ID 2 ²	DIP-2 = ID 2 ¹	DIP-1 = ID 2 ⁰	Address = ID
off	off	off	off	off	off	1
off	off	off	off	off	on	2
off	off	off	off	on	off	3
.
on	on	on	on	on	off	63
on	on	on	on	on	on	64

SW3 Baud rate			
DIP-2	DIP-1	Baud rate	Line length [m]
off	off	20 kbps	up to 2500
off	on	125 kbps	up to 500
on	off	500 kbps	up to 100
on	on	1000 kbps	up to 25

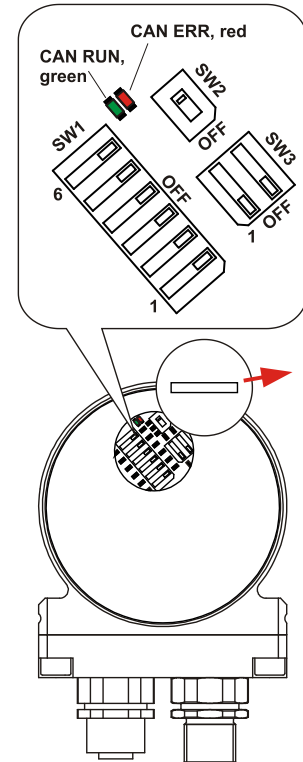

Bus Status:

LED	Definition
ON	constantly ON
OFF	constantly OFF
Blinking	equal ON and OFF times with a frequency of 2.5 Hz: ON = 200 ms, OFF = 200 ms.
Single flash	one short flash, 200 ms ON, followed by a long OFF phase, 1000 ms.
Double flash	double short blinking, each 200 ms ON and OFF
Triple flash	triple short blinking, each 200 ms ON and OFF
Flickering	equal ON and OFF times with a frequency of 10 Hz: ON = 50 ms, OFF = 50 ms.
Flicker flash	every 5000 ms for 500 ms Flickering (overlays the LED-states above)

green	CAN RUN-LED
ON	Device is ready for operation and is in state OPERATIONAL-Mode
OFF	No supply, hardware error
Blinking	Device is in state PRE-OPERATIONAL-Mode
Single flash	CAN communication stopped, the device is in state STOPPED-Mode
Triple flash	Boot loader active (software download in progress)
Flickering	LSS configuration active
Flicker flash	Node-ID and baud rate over LSS active

red	CAN ERR-LED
ON	Bus offline, no bus connection
OFF	No error
Single flash	to much errors over the CAN-controller
Double flash	Node Guarding or Heartbeat error
Flickering	device hardware error (such as: measuring- or EEPROM error)