

Connector pin assignment CAN-BUS Encoder

Wiring variants see back

Print clamps: 2-pole, grid spacing 5,08 mm, nominal cross-section 0,14-1,5 mm² (fixed or flexible), nominal voltage 250 V, rated current 16 A, AWG 26-16

X1 - screw clamp 2-pin

- Pin 1 CAN_US
- Pin 2 CAN_GND

X2 - screw clamp 2-pin

- Pin 1 CAN_H
- Pin 2 CAN_L

X3 - screw clamp 2-pin

- Pin 1 screening
- Pin 2 screening

X4 - screw clamp 2-pin

- Pin 1 CAN_L
- Pin 2 CAN_H

X5 - screw clamp 2-pin

- Pin 1 CAN_GND
- Pin 2 CAN_US

X6 - screw clamp 2-pin

- Pin 1 US, supply voltage 11 - 27 V DC
- Pin 2 GND, supply voltage 0 V

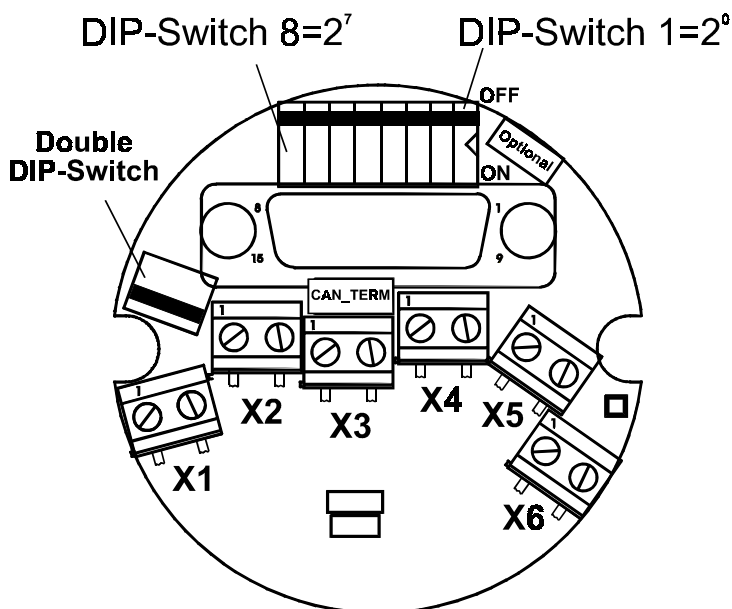

Identifier

DIP-switch 6 = identifier 2 ⁵	DIP-switch 5 = identifier 2 ⁴	DIP-switch 4 = identifier 2 ³	DIP-switch 3 = identifier 2 ²	DIP-switch 2 = identifier 2 ¹	DIP-switch 1 = identifier 2 ⁰	Encoder address = identifier
off	off	off	off	off	off	0
off	off	off	off	off	on	1
off	off	off	off	on	off	2
.
on	on	on	on	on	off	62
on	on	on	on	on	on	63

Baud rate

DIP-switch 8	DIP-switch 7	Baud rate
off	off	500 kbps
off	on	125 kbps
on	off	250 kbps
on	on	20 kbps

CAN-TERMINATOR

	TERMINATOR: ON	TERMINATOR: OFF
Terminating impedance	YES: 123 Ω between CAN_L and CAN_H	NO

Double DIP-Switch

on	without galvanic separation
off	galvanic separation

Wiring variants

1. Galvanic separation

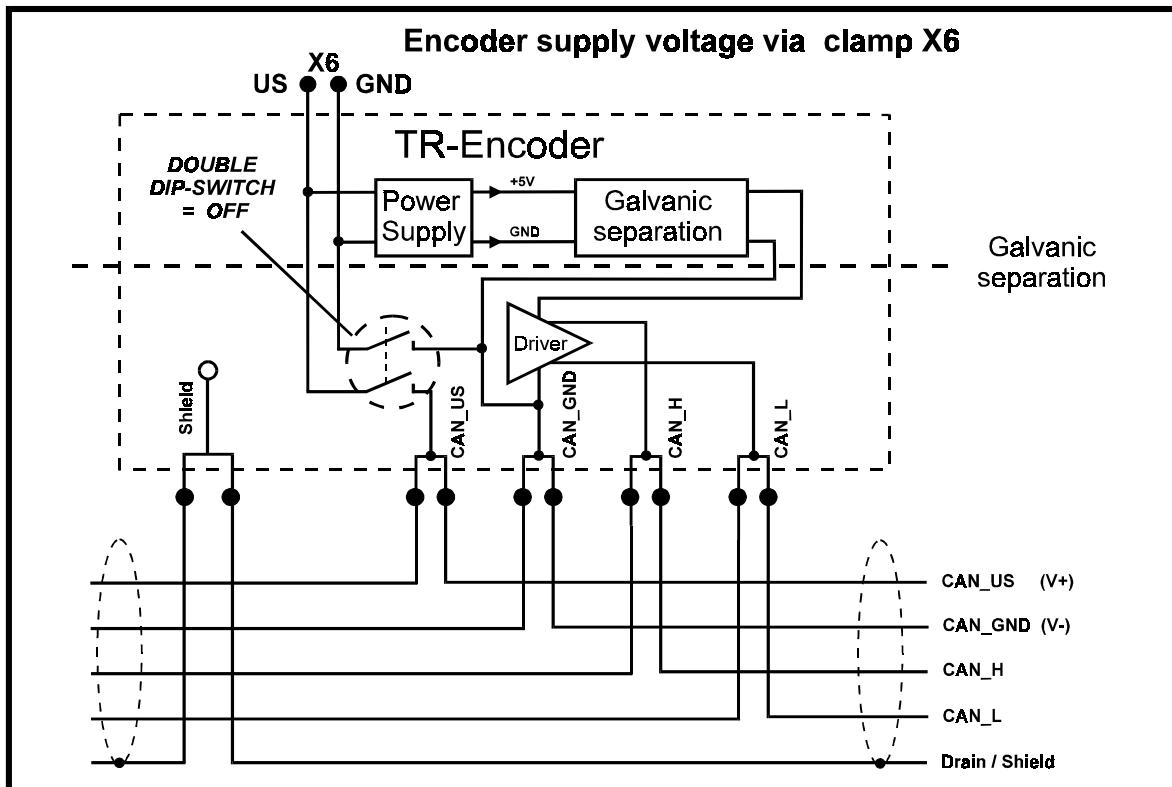

2. Without galvanic separation

