

Connector pin assignment ZH-81 Profibus encoder according to PNO-Profile Class 2 with SSI-interface and incremental signals (Push-Pull)

If the encoder is the last station in the profibus line, the DIP switch *sw1* for the profibus terminator (switching-on of the terminal resistance) must be switched on. Otherwise he must be switched off. In order to enable a separate wiring of incoming and outgoing signals the profibus terminals and the terminals for the supply voltage have two connection possibilities.

TR-Electronic recommends for the operation to use only bus cables certified by the Profibus User Organization (PNO). For the + and -signals of the RS422, RS485 and incremental data twisted core pairs are to be used.

With the BCD address switches 10^0 and 10^1 the station address for the profibus is set from 3 to 99.

Print Spring-Force-terminals

Spacing grid:	2,54 mm		
Nominal voltage / -current:	63 V / 6 A at a nominal cross-section of 0,5 mm ²		
Connection:	inflexible: 0,14 - 0,5 mm ²	flexible: 0,14 – 0,5 mm ²	Conductor size (AWG): 26 - 20
	flexible with wire end sleeve without plastic sleeve:	flexible with wire end sleeve with plastic sleeve:	

Explanation of terms:

ZH-81: Absolute Hollow Shaft Encoder
 US: Supply voltage, 11-27 V DC
 US-input: 1-level > +8V, 0-level < +2V, up to ±35V, 5 kOhm
 US-output: 1-level > US-2V, 0-level < 1 V, up to 100mA
 Opto-input: Opto coupler for cable driver- or TTL differential signals

X1 - 9-pole

Pin 1 RS422-output for SSI-data +
 Pin 2 RS422-output for SSI-data –
 Pin 3 *Do not connect!*
 Pin 4 US-output, Channel 0 +
 Pin 5 US-output, Channel 0 –
 Pin 6 US-output, Channel 1 +
 Pin 7 US-output, Channel 1 –
 Pin 8 US-output, Channel 2 +
 Pin 9 US-output, Channel 2 –

X2 - 9-pole

Pin 1 RS485 for PC-adapter and EPROG +
 Pin 2 RS485 for PC-adapter and EPROG –
 Pin 3 *Do not connect!*
 Pin 4 US-input for Preset 1
 Pin 5 US-input for Preset 2
 Pin 6 GND, supply voltage 0 V
 Pin 7 US, supply voltage
 Pin 8 GND, supply voltage 0 V
 Pin 9 US, supply voltage

X3 - 9-pole

Pin 1 Opto-input for SSI-clock –
 Pin 2 Opto-input for SSI-clock +
 Pin 3 Profibus M5V2
 Pin 4 Profibus DataA
 Pin 5 Profibus DataB
 Pin 6 Profibus M5V2
 Pin 7 Profibus DataA
 Pin 8 Profibus DataB
 Pin 9 GND, supply voltage 0 V

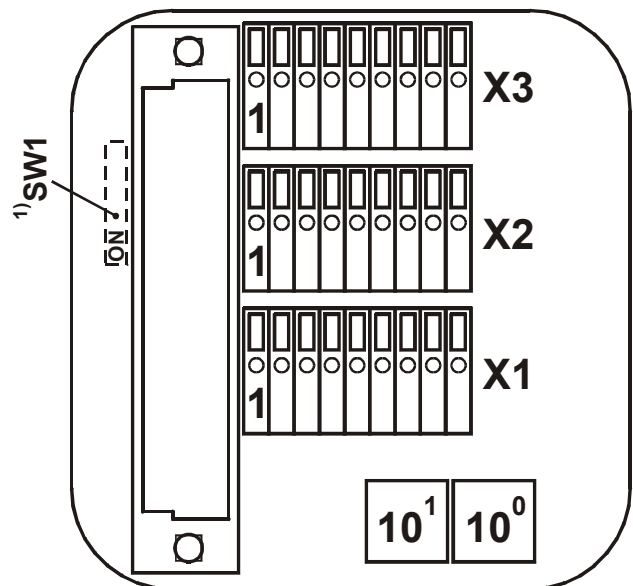

1): DIP-switch, solder side for termination