

LP-38 Profibus-DP PNO Class 2 with connection box **(valid before 12/2007)**

General note:

If the linear-encoder is the last station in the profibus line, the DIP switches *S1* and *S2* for the profibus terminator (switching-on of the terminal resistance) must be switched on. Otherwise they must be switched off.

In order to enable a separate wiring of incoming and outgoing signals the profibus terminals and the terminals for the supply voltage have two connection possibilities.

Remove not used screw joints and close boring with enclosed dummy plugs.

With the BCD address switches *SW2* (10^1) and *SW1* (10^0) the station address for the profibus is set from 3 to 99.

Explanation of terms:

LP-38: Linear-Encoder with 38 mm profile housing
 US: Supply voltage, 19-27 V DC

X1 - screw clamp 2-pin

Pin 1 US, supply voltage
 Pin 2 GND, supply voltage 0 V

X2 - screw clamp 2-pin

Pin 1 GND, supply voltage 0 V
 Pin 2 US, supply voltage

X3 - screw clamp 2-pin

Pin 1 Profibus DataA
 Pin 2 Profibus DataB

X4 - screw clamp 2-pin

Pin 1 Profibus DataB
 Pin 2 Profibus DataA

LED-Status

green: ready for operation
 flashing red: Profibus master does not address encoder
 red: the encoder has no magnet detected

Address switches

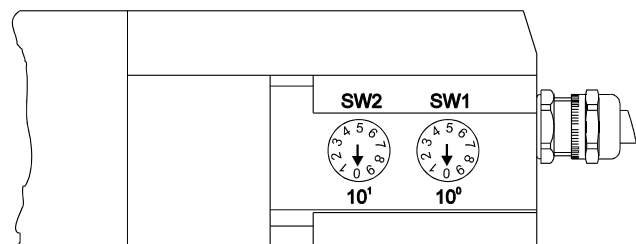

Connections

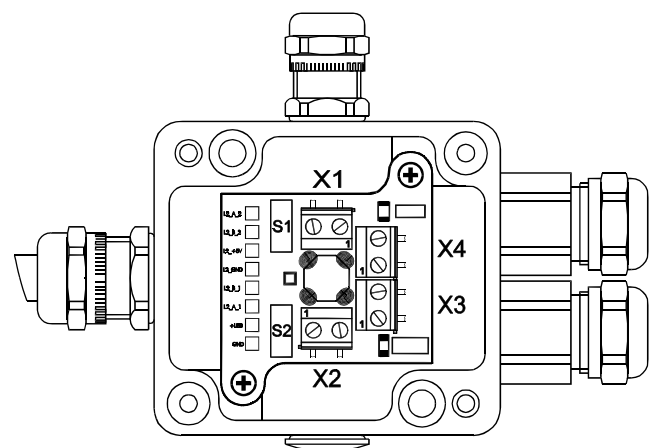

LP-38 Profibus-DP PNO Class 2 with connection box (valid from 12/2007)

General note:

If the measuring system is the last station in the Profibus segment, the DIP switch *SW3* for the Profibus terminator (switching-on of the terminal resistance) must be switched on. Otherwise the terminator must be switched off. With the add-on connection of the terminal resistance the Profibus signals DataA_OUT and DataB_OUT will be switched off and following slaves are separated from the bus. In order to enable a separate wiring of incoming and outgoing signals the Profibus terminals and the terminals for the supply voltage have two connection possibilities.

TR-Electronic recommends for the operation to use only bus cables certified by the Profibus User Organization (PNO). Remove not used screw joints and close boring with enclosed dummy plugs.

With the BCD address switches *SW2* (10^1) and *SW1* (10^0) the station address for the Profibus is set from 3 to 99.

X1	Screw terminal, 2-pole	
Pin 1	19 – 27 V DC	Supply Voltage
Pin 2	GND, 0V	

X2	Screw terminal, 2-pole	
Pin 1	GND, 0V	Supply Voltage
Pin 2	19 – 27 V DC	

X3	Screw terminal, 2-pole	
Pin 1	Profibus, Data A	Profibus_IN
Pin 2	Profibus, Data B	

X4	Screw terminal, 2-pole	
Pin 1	Profibus, Data B	Profibus_OUT
Pin 2	Profibus, Data A	

