

Laser-Entfernungs-Messgerät LE-200 CANopen

Allgemeine Hinweise:

Die CAN-Bus-Leitung (CAN_H und CAN_L) ist am Anfang bzw. am Ende mit einem Abschlusswiderstand (**CAN-TERMINATOR**) von 121 Ohm abzuschließen.

Für die Installation sind die Hinweise der CANopen Spezifikation „cin DR 303-1“ zu beachten!

Bei langen Leitungslängen kann die separate Mitführung des CAN_GND – Signals erforderlich werden. In diesem Fall muss nach Steckerbelegung „TR-ELE-TI-D-0010“ verdrahtet werden und das Gerät entsprechend ausgetauscht werden.

X1/X2	X1 CANopen_IN, M12-Stecker (M12x1-5 pol. A-kodiert)	X2 CANopen_OUT, M12-Buchse (M12x1-5 pol. A-kodiert)
1	CAN Shield, großflächig auf Stecker- gehäuse auflegen !	
2	US-Versorgung, 18-27 V DC	
3	0V-Versorgung	
4	CAN_H	
5	CAN_L	

X3	Schaltsignale, Programmierschnittstelle, M12-Stecker (M12x1-8 pol. A-kodiert)	
1	Signal GND (Bezugspotential Pin 2)	
2	Schaltausgang; 1-Pegel > US-2V, 0-Pegel < 1 V, bis zu 100mA	
3	Schalteingang; 1-Pegel > +8V, 0-Pegel < +2V, bis zu ±35V, 5 kOhm	
4	RS485 -, TRWinProg	
5	RS485 +, TRWinprog	
6-8	N.C.	

Identifizier (ID), Adressierung						
DIP-6 = ID 2 ⁵	DIP-5 = ID 2 ⁴	DIP-4 = ID 2 ³	DIP-3 = ID 2 ²	DIP-2 = ID 2 ¹	DIP-1 = ID 2 ⁰	Adresse = ID
off	off	off	off	off	off	1
off	off	off	off	off	on	2
off	off	off	off	on	off	3
⋮	⋮	⋮	⋮	⋮	⋮	⋮
on	on	on	on	on	off	63
on	on	on	on	on	on	64

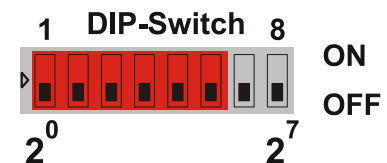

Baudrate			
DIP-8	DIP-7	Baudrate	Leitungslänge [m]
off	off	20 kBaud	bis 2500
off	on	125 kBaud	bis 500
on	off	500 kBaud	bis 100
on	on	1 MBaud	bis 25

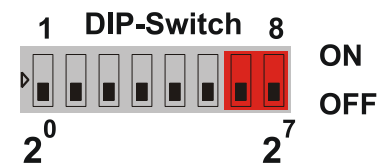

Status-LEDs	
Alle LEDs aus	Laser nicht On-Line - Evt. keine Laser-Spannungsversorgung
RUN , grün	Laser On-Line, gewählte Verbindung aufgebaut - Zuordnung zu einem Master
RUN , grün blinkend	Behebbarer Fehler - z.B.: Die I/O-Verbindung ist im Time-out-Zustand (Bei aktivem Node-Guarding)
ERR , rot	- System abschalten, danach wieder einschalten - Laser-Gerät ersetzen
ERR , rot blinkend	- Off-Line
OK , grün	Laser Hardware ok

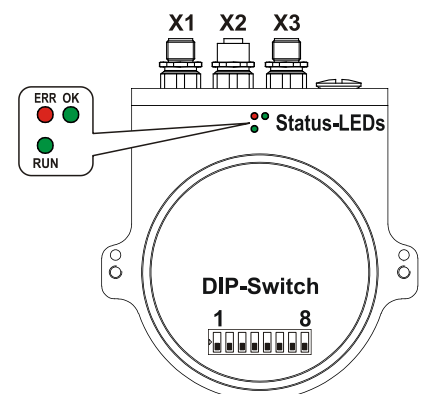

Laser Measuring Device LE-200 CANopen

General note:

The CAN-Bus line (CAN_H / CAN_L) has to be terminated at the beginning or at the end with a terminating resistor of 121 ohms (**CAN-TERMINATOR**).

For installation the references of the CANopen specification "**ciA** DR 303-1" are to be observed!

In case of long cable length it can be necessary to connect the signal CAN_GND separately. In this connection it must be wired according to the pin assignment "TR-ELE-TI-GB-0010", the device must be replaced correspondingly.

X1/X2	X1 CANopen_IN, M12 male (M12x1-5 pol. A-coded)	X2 CANopen_OUT, M12 female (M12x1-5 pol. A-coded)
1	CAN Shield, connect large-area onto connector housing !	
2	US-Supply Voltage, 18-27 V DC	
3	0V-Supply Voltage	
4	CAN_H	
5	CAN_L	

X3	Switching signals, Programming interface, M12 male (M12x1-8 pol. A-coded)
1	Signal GND (reference potential pin 2)
2	Switching output; 1-level > US-2V, 0-level < 1 V, up to 100mA
3	Switching input; 1-level > +8V, 0-level < +2V, up to ±35V, 5 kOhm
4	RS485 -, TRWinProg
5	RS485 +, TRWinprog
6-8	N.C.

Identifier (ID), Addressing						
DIP-6 = ID 2 ⁵	DIP-5 = ID 2 ⁴	DIP-4 = ID 2 ³	DIP-3 = ID 2 ²	DIP-2 = ID 2 ¹	DIP-1 = ID 2 ⁰	Address = ID
off	off	off	off	off	off	1
off	off	off	off	off	on	2
off	off	off	off	on	off	3
⋮	⋮	⋮	⋮	⋮	⋮	⋮
on	on	on	on	on	off	63
on	on	on	on	on	on	64

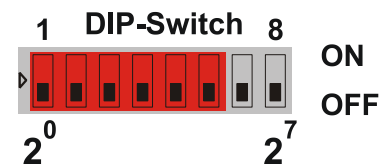

Baud rate			
DIP-8	DIP-7	Baud rate	Line length [m]
off	off	20 kbps	up to 2500
off	on	125 kbps	up to 500
on	off	500 kbps	up to 100
on	on	1000 kbps	up to 25

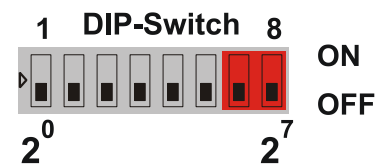

Status LEDs	
LEDs Off	Laser is not on-line - Device may not be powered
RUN , green	On-line, with connections in the established state - Device is allocated to a master
RUN , green flashing	Recoverable fault - e.g. I/O-connections are in the time-out state (Node-Guarding active)
ERR , red	- Turn off system, after that turn on system - Replace laser device
ERR , red flashing	- Off-Line
OK , green	Laser hardware ok

