

**Pin assignment Laser Measuring Devices (LE) Profibus-DP**

*General note:*

If the device is the last station in the profibus line, the DIP switches *S3* and *S4* for the profibus terminator (switching-on of the terminal resistance) must be switched on. Otherwise they must be switched off and the terminating resistor (220 ohms) in the mating connector (8-pole) equipped by the delivery must be taken.

The profibus also works when the device is removed. Is the device the last station in the profibus line, the reference potential of the terminator resistances is missing!

TR-Electronic recommends for the operation to use only bus cables certified by the PNO. With the BCD address switches *S1* ( $10^1$ ) and *S2* ( $10^0$ ) the station address for the profibus is set from 3 to 99.

*Explanation of terms:*

COMBICON 4 / 8-pole:	Connector Phoenix COMBICON 12A/250V, grid 5.08 mm		
Connection:	inflexible 0,2 - 2,5 mm <sup>2</sup>	flexible 0,2 - 2,5 mm <sup>2</sup>	Conductor size (AWG) 24 - 12
	flexible with wire end sleeve without plastic sleeve: -	flexible with wire end sleeve with plastic sleeve: -	
US:	Supply voltage: Standard device: 18 - 27 V DC, Device with heating: 24 C DC		
US-input:	1-level > +8V, 0-level < +2V, up to ±35V, 5 kOhm		
Opto-input:	Opto coupler for cable transmitter (RS422)		
RS422-output:	see DIN 66 348, part 2		

**X1 - COMBICON 8-pole**

- Pin 1 Profibus DataB
- Pin 2 Profibus DataA
- Pin 3 Programming interface RS485 -
- Pin 4 Programming interface RS485 +
- Pin 5 US-input for Preset 1
- Pin 6 US-input hardware acknowledgement
- Pin 7 US, supply voltage
- Pin 8 GND, supply voltage 0 V

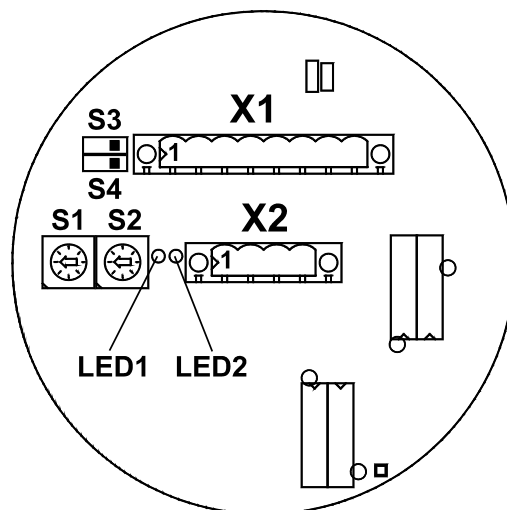

**X2 - COMBICON 4-pole (Function optional)**

- Pin 1 Opto-input for SSI-clock-
- Pin 2 Opto-input for SSI-clock +
- Pin 3 RS422-output for SSI-data +
- Pin 4 RS422-output for SSI-data -

**Range selector switch**

- OFF: <100m
  - ON : >100m: Do not move the measuring system in the voltage-loose state below or above the 100m mark!
- The non-compliance leads to measuring errors, the measuring system must be moved back into the range as described.