

Steckerbelegung Stellantrieb / Pin Assignment Servo Drive

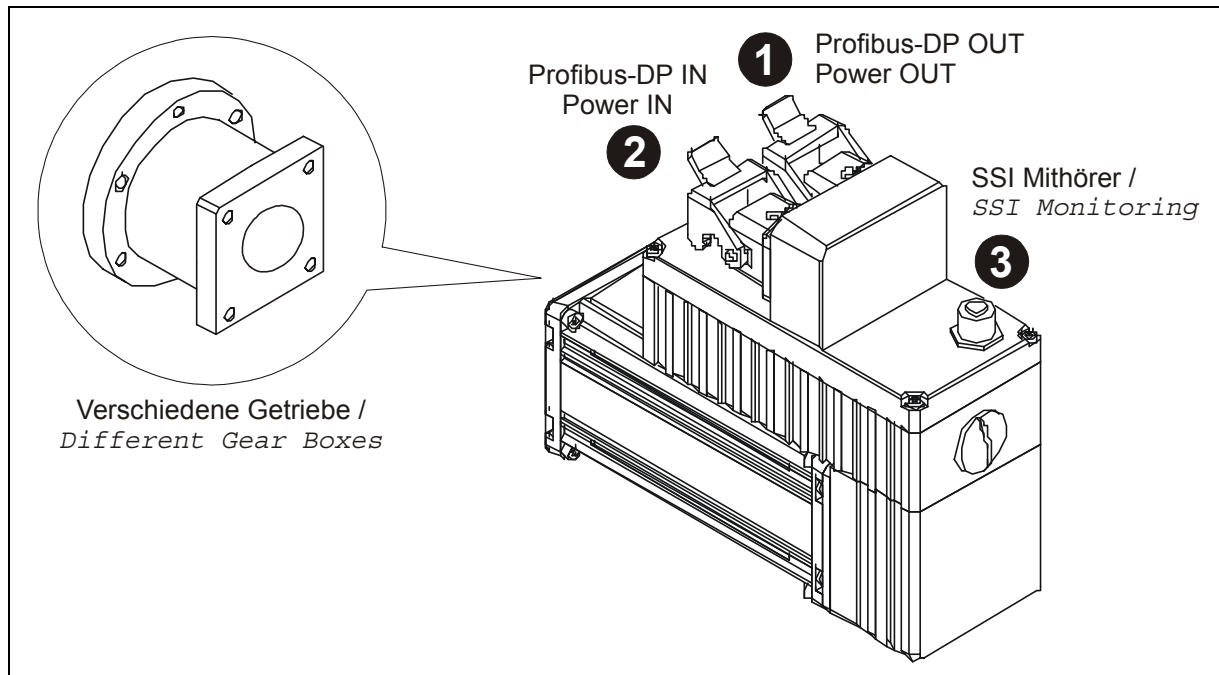

1 Buchse / Female Connector Han-Brid® Cu
Profibus OUT, Versorgung OUT / Profibus OUT, Power OUT

A	Profibus, Data A
B	Profibus, Data B
1	+24 V
2	0 V
3	0 V
4	+24 V

intern gebrückt /
internally connected:
 Pin 1/4, Pin 2/3

Steckseite / Mating Face

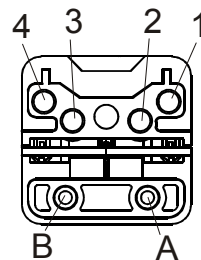

2 Stift / Male Connector Han-Brid® Cu
Profibus IN, Versorgung IN / Profibus IN, Power IN

A	Profibus, Data A
B	Profibus, Data B
1	+24 V
2	0 V
3	0 V
4	+24 V

intern gebrückt /
internally connected:
 Pin 1/4, Pin 2/3

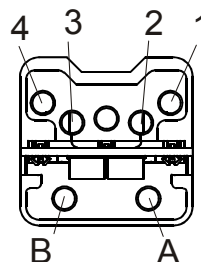

3 Buchse / Female Connector Binder Series 713 (M12x1-5 pol.)
SSI-Mithörer / SSI-Monitoring

1	SSI-Takt - / SSI-Clock -
2	SSI-Takt + / SSI-Clock +
3	SSI-Daten + / SSI-Data +
4	SSI-Daten - / SSI-Data -
5	Ground, GND

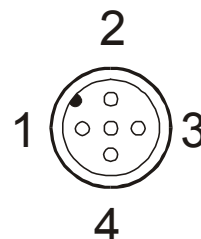

SSI-Einstellungen / SSI-Settings

Taktimpulse = 25	Clock pulses = 25
Taktfrequenz = 312,5 kHz	Clock frequency = 312.5 kHz
Code = Binär	Code = Binary

Profibus-Adresse, Busabschluss / Profibus Address, Bus Termination

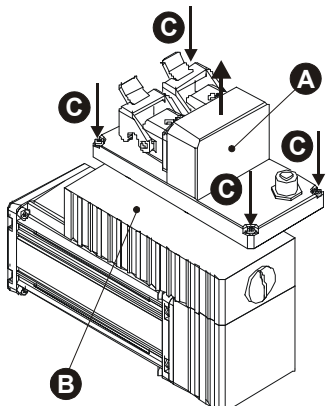
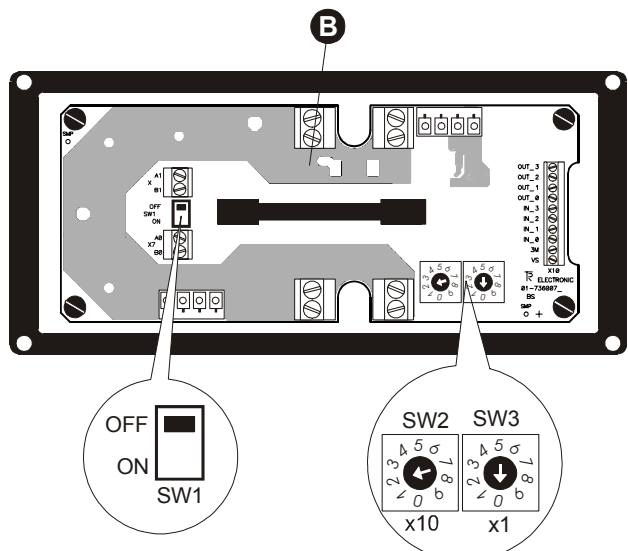



Schrauben (C) lösen und Deckel (A) abheben

Loosen the screws (C) and take off the cover (A)

- Über die Adress-Schalter SW2 und SW3 im Unterteil (B) die Profibus-Adresse einstellen. SW2 = 10¹ / SW3 = 10⁰. Gültige Profibus-Adressen = 3 - 99.
- Einschaltung des Abschluss-Widerstandes über SW1, wenn das Gerät der erste oder letzte Teilnehmer in der Bus-Linie ist. Der abgehende Bus wird dabei unterbrochen.
- Adjust the Profibus address via the address switches SW2 and SW3 in the bottom part (B). SW2 = 10¹ / SW3 = 10⁰. Valid Profibus addresses = 3 - 99.
- Switching-on of the terminal resistance via SW1, if the device is the first or last subscriber in the bus line. Thereby, the outgoing bus is interrupted.

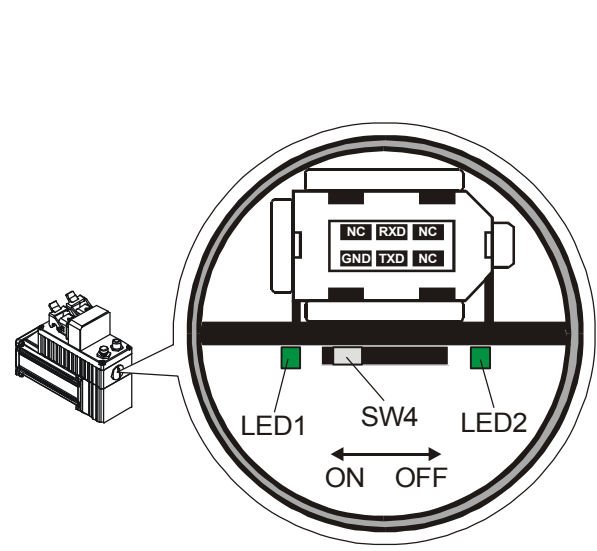
Schnittstelle / Interface IEEE-1394



LED1 (grün/green)	Diagnose / Diagnostics
an / on:	- 10% an: Störung im Handbetrieb / - 10% on: Failure in manual mode - 50% an: keine Busverbindung / - 50% on: No bus connection - 90% an: Störung im Busbetrieb / - 90% on: Failure in bus mode - 100% an: Betriebsbereit / - 100% on: Ready
aus / off:	- Antrieb ausgeschaltet / Drive switched off - Antrieb defekt / Drive failure
LED2 (grün/green)	CPU-Fehler / CPU Error
an / on:	Versorgungsspannung o.k. / Supply voltage o.k.
aus / off:	- Antrieb ausgeschaltet / Drive switched off - Antrieb defekt / Drive failure
SW4	Mode-Schalter / Mode Switch
an / on:	Betrieb / Operation
aus / off:	Firmwareupdate / Firmware update