

Kugel herausnehmbar
removable ball

M16x1.5, SW20, für Kabel/for cable Ø5-10

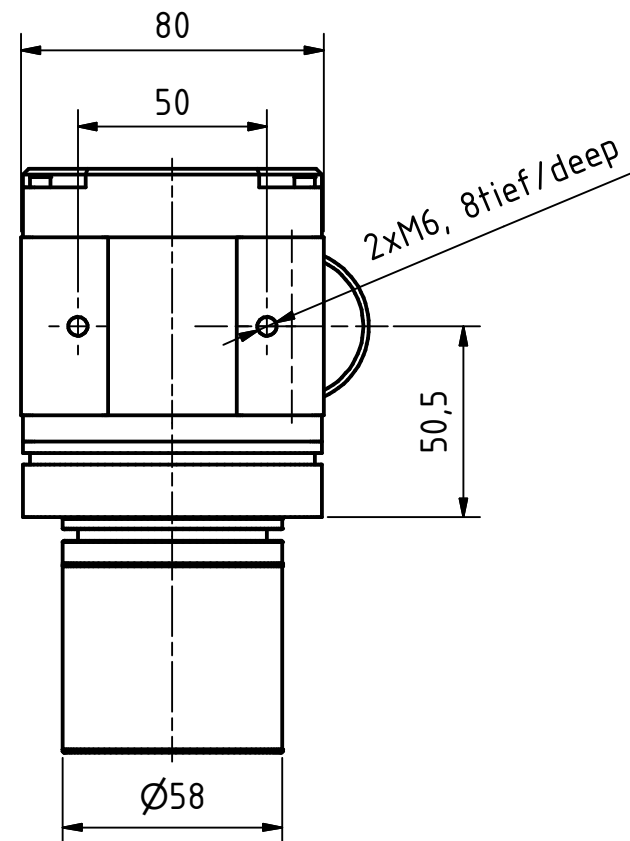

Biegeradius Kabel 15xØ bezogen auf Standardkabel
Unitronic FD-CP
Bending cable radius 15xØ for cable type
Unitronic FD-CP

Seillänge 2m
Übersetzung ca. 5Umdr./m
(individueller Wert siehe Typenschild)
Übers.-Genauigkeit 0.05%
Feder-Rückzugkraft 7N (Anfang)/14N (Ende)
max. Verstellgeschwindigkeit 2m/s
Seildurchmesser 1.35

cable length 2m
gear ratio ca. 5Umdr./m
(individual value see type plate)
accuracy gear ratio 0.05%
spring pull-back power 7N (Anfang)/14N (Ende)
max. control speed 2m/s
cable Ø 1.35

Artikel-Nr. und Steckerbelegung: siehe Datenblatt
Article-No. and pin connections: see data sheet

 TR-electronic GmbH Eglisshalde 6 D-78647 Trossingen phone +49 7425 228.0 www.tr-electronic.de	Maßstab 1:2 DIN A3 Projekt-Nr.:																
	Zeichnungs-Nr. nur für diese Ausführung gültig Drawing-No. only for this type valid																
<table border="1"> <thead> <tr> <th></th> <th>Datum</th> <th>Name</th> </tr> </thead> <tbody> <tr> <td>Erstellt</td> <td>11.04.2019</td> <td>FLAIG</td> </tr> <tr> <td>Bearb.</td> <td>11.04.2019</td> <td>FLAIG</td> </tr> <tr> <td>Gepr.</td> <td>11.04.2019</td> <td>NEMECZ</td> </tr> <tr> <td>Norm</td> <td></td> <td></td> </tr> </tbody> </table>		Datum	Name	Erstellt	11.04.2019	FLAIG	Bearb.	11.04.2019	FLAIG	Gepr.	11.04.2019	NEMECZ	Norm			CMW-582-M, pull of rope encoder 0-2m rope	
	Datum	Name															
Erstellt	11.04.2019	FLAIG															
Bearb.	11.04.2019	FLAIG															
Gepr.	11.04.2019	NEMECZ															
Norm																	
www.tr-electronic.de DXF+Info: info@tr-electronic.de	Zeichnungs-NR./Drawing-No.: 04-CMW582M-M0048																
Zustf. Änderungen Datum Name	Blatt 1 1 Bl																