

Pin assignment

Laser Measuring Device LE-200 DeviceNet™

General note:

The CAN-Bus line (CAN_H / CAN_L) has to be terminated at the beginning or at the end with a terminating resistor of 121 ohms (**CAN-TERMINATOR**). In order to enable a separate wiring of the incoming and outgoing signals the CAN_H / CAN_L - terminals have two connection possibilities.

Explanation of terms			
SMKDS 1-3,5:	Print-Clamp Phoenix Contact 10A/160V, grid 3.5 mm, connection direction 55°		
Connection:	inflexible 0,14 - 1,5 mm ²	flexible 0,14 - 1 mm ²	Conductor size (AWG) 26 - 16
	flexible with wire end sleeve without plastic sleeve: 0,25 - 0,5 mm ²		flexible with wire end sleeve with plastic sleeve: 0,25 - 0,5 mm ²
US:	Supply Voltage Standard Device: 18 - 27 V DC, device with heating: 24 V DC (± 5%)		
US-input:	1-level > +8 V, 0-level < +2 V, up to ±35 V, 5 kOhm		
US-output:	1-level > US-2 V, 0-level < 1 V, up to 100 mA		
GNDI / GND	galvanically from each other separated data reference potentials		

X1	Screw Clamp, 20-pole	
Pin 1 Pin 2 Pin 3	Signal GND (reference potential pin 2) US-output US-input	Switching input / Switching output, programmable
Pin 4-6 + Pin 11-14	N.C.	may not be connected !
Pin 7 Pin 8	0V-supply voltage US-supply voltage	Supply Voltage
Pin 9 Pin 10	RS485 – RS485 +	Programming Interface, TRWinProg
Pin 15 Pin 16 Pin 17 Pin 18 Pin 19 Pin 20	GNDI (reference potential of the CAN_L / CAN_H signals) Shield (internal via RC-element onto case) CAN_H CAN_H CAN_L CAN_L	CAN – Bus / Shielding

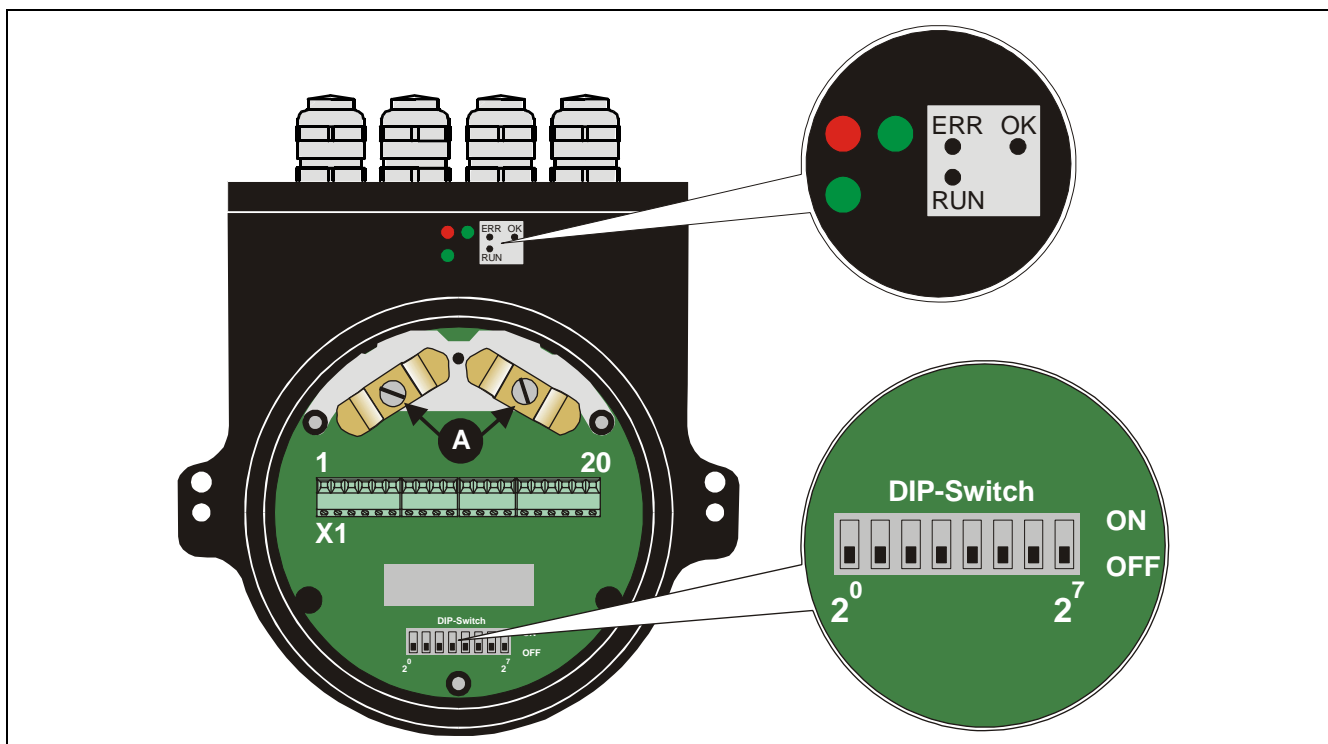

Pin assignment

Identifier (ID), Laser addressing						
DIP-6 = ID 2^5	DIP-5 = ID 2^4	DIP-4 = ID 2^3	DIP-3 = ID 2^2	DIP-2 = ID 2^1	DIP-1 = ID 2^0	Address = ID
off	off	off	off	off	off	0
off	off	off	off	off	on	1
off	off	off	off	on	off	2
⋮	⋮	⋮	⋮	⋮	⋮	⋮
on	on	on	on	on	off	62
on	on	on	on	on	on	63

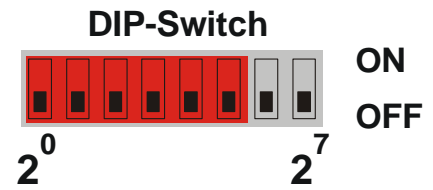

Baud rate			
DIP-8	DIP-7	Baud rate	Line length
off	off	125 kbps	approx. 500 m
off	on	250 kbps	approx. 250 m
on	off	500 kbps	approx. 100 m

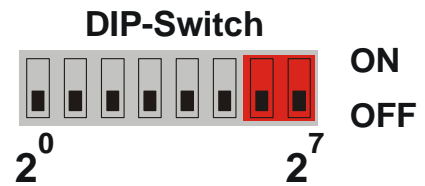

Status LEDs	
LEDs Off	Laser is not On-Line - No Dup_MAC_ID test - Device may not be powered
RUN , green	On-line, with connections in the established state - Device is allocated to a master
RUN , green flashing	Recoverable faults - e.g. I/O-connections are in the time-out state
ERR , red	- Turn off system, after that turn on system - Replace laser device
ERR , red flashing	- Dup-MAC-ID test successful - No allocation to a master
OK , green	Laser hardware ok

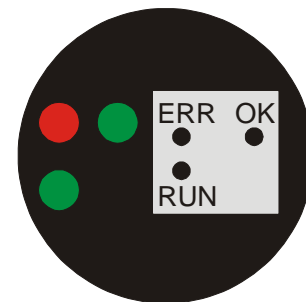

Wiring diagram, Bus connection

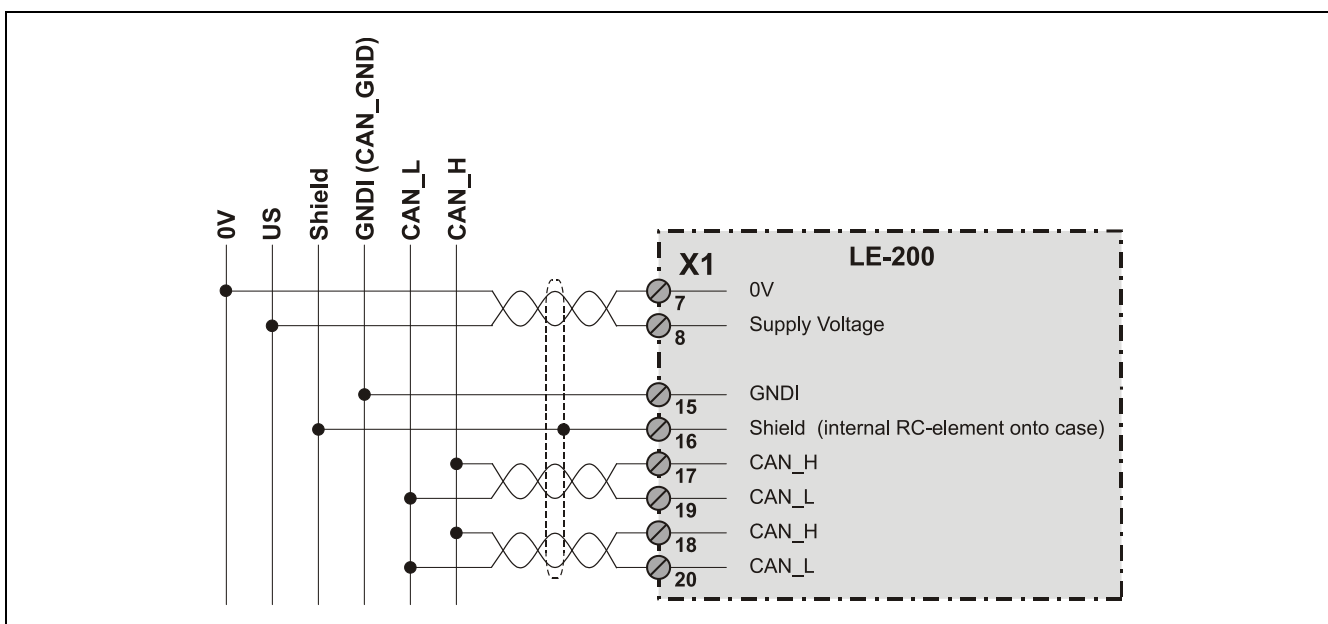

Subject to change