

Technical Information

Connector pin assignment Laser Measuring Device LE-200 CANopen

General note:

The CAN-Bus line (CAN_H / CAN_L) has to be terminated at the beginning or at the end with a terminating resistor of 121 ohms (**CAN-TERMINATOR**). In order to enable a separate wiring of the incoming and outgoing signals the CAN_H / CAN_L - terminals have two connection possibilities.

Explanation of terms			
SMKDS 1-3,5:	Print-Clamp Phoenix Contact 10A/160V, grid 3.5 mm, connection direction 55°		
Connection:	inflexible 0,14 - 1,5 mm ²	flexible 0,14 - 1 mm ²	Conductor size (AWG) 26 - 16
	flexible with wire end sleeve without plastic sleeve: 0,25 - 0,5 mm ²		flexible with wire end sleeve with plastic sleeve: 0,25 - 0,5 mm ²
US:	Supply Voltage Standard Device: 18 - 27 V DC, device with heating: 24 V DC (± 5%)		
US-input:	1-level > +8V, 0-level < +2V, up to ±35V, 5 kOhm		
US-output:	1-level > US-2V, 0-level < 1 V, up to 100mA		
GNDI / GND	galvanically from each other separated data reference potentials		

X1	Screw Clamp, 20-pole	
Pin 1 Pin 2 Pin 3	Signal GND (reference potential pin 2) US-output US-input	Switching input / Switching output, programmable
Pin 4-6 + Pin 11-14	N.C.	may not be connected !
Pin 7 Pin 8	0V-supply voltage US-supply voltage	Supply Voltage
Pin 9 Pin 10	RS485 – RS485 +	Programming Interface, TRWinProg
Pin 15 Pin 16 Pin 17 Pin 18 Pin 19 Pin 20	GNDI (reference potential of the CAN_L / CAN_H signals) Shield (internal via RC-element onto case) CAN_H CAN_H CAN_L CAN_L	CAN – Bus / Shielding

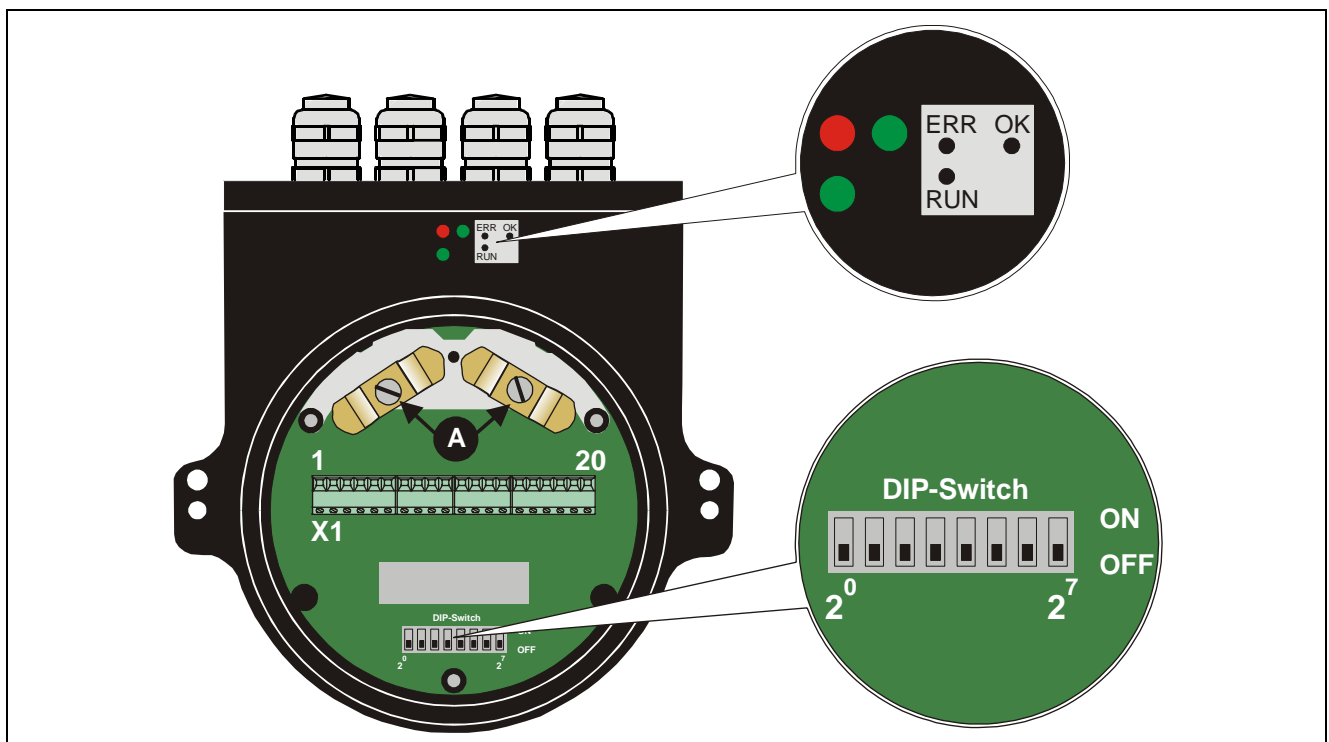

Technical Information

Identifier (ID), Laser addressing						
DIP-6 = ID 2 ⁵	DIP-5 = ID 2 ⁴	DIP-4 = ID 2 ³	DIP-3 = ID 2 ²	DIP-2 = ID 2 ¹	DIP-1 = ID 2 ⁰	Address = ID
off	off	off	off	off	off	1
off	off	off	off	off	on	2
off	off	off	off	on	off	3
⋮	⋮	⋮	⋮	⋮	⋮	⋮
on	on	on	on	on	off	63
on	on	on	on	on	on	64

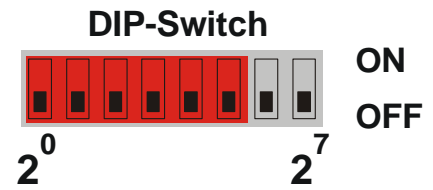

Baud rate			
DIP-8	DIP-7	Baud rate	Line length [m]
off	off	20 kbps	up to 2500
off	on	125 kbps	up to 500
on	off	500 kbps	up to 100
on	on	1000 kbps	up to 25

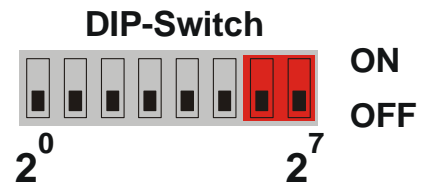

Status LEDs	
LEDs Off	Laser is not on-line - Device may not be powered
RUN , green	On-line, with connections in the established state - Device is allocated to a master
RUN , green flashing	Recoverable fault - e.g. I/O-connections are in the time-out state (Node-Guarding active)
ERR , red	- Turn off system, after that turn on system - Replace laser device
ERR , red flashing	- Off-Line
OK , green	Laser hardware ok

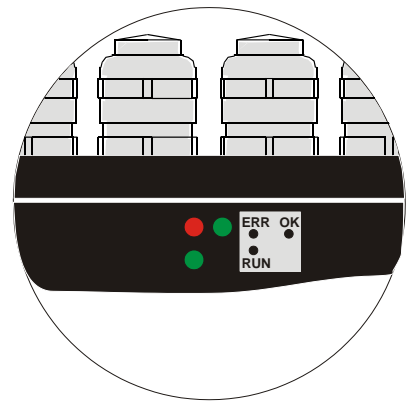

Wiring diagram, Bus connection

