

Couplings

Type WK2 20/33



Stock photo

Document-/Rev.-No.:

TR-V-TI-GB-0421 v04

05/13/2025

Advantages

- Backlash-free transmission of torque
- High torsional stiffness, precision of transmission of rotation angle
- Small dimensions, low moment of inertia
- Compensations of radial, axial and angular misalignment
- Free of wear, maintenance-free, no standstill periods
- Simple and operationally safe assembly

Description

The coupling connects two shafts backlash-free with shaft-hub-connection over tread pins.

The metal bellows are made of anti-corrosive steel, all other parts are manufactured from aluminum or steel and partly have an environmental friendly protective coating.

As a standard, the boreholes are equipped with a fitting in accordance with ISO-H7. For the shafts, we recommend a transition, e.g. H7/g6. When selecting other shaft fitting, the fitting should not exceed a maximum of 0.03 mm.

The power transmission between the coupling hub and the shaft occurs through compression and friction between the contact surfaces. Special attention must be paid to the tightening torque of the retaining screws as well as the perfect condition of the contact surfaces. The contact surfaces must be free of oil and grease. Types with a keyway are available.

Subject to change.

Couplings

Type WK2 20/33

Document-/Rev.-No.:

TR-V-TI-GB-0421 v04

05/13/2025

Mechanical characteristic Data

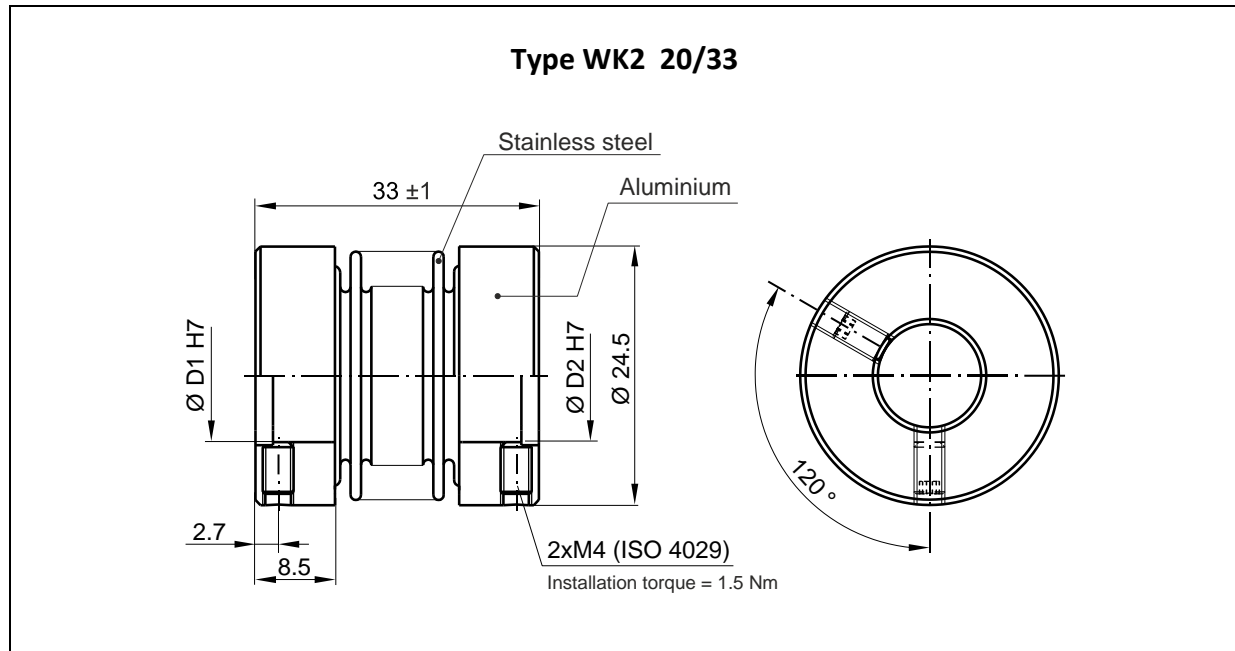

Nominal torque	Misalignment			Torsion spring stiffness	Moment of inertia	Weight	Rotational speed max.	Temperature range
	radial ΔK_r	axial ΔK_a	angle ΔK_w					
Nm	mm	mm	°	Nm/rad	g cm ²	g	min ⁻¹	°C
2	0.2	0.4	1.5	1300	23	24	15,000	-30 to +120

Type	Ø D1 H7	Ø D2 H7	Article-No.
WK2 20/33	6	6	34000164
	6	8	34000191
	6	10	34000165
	6	12	34000177
	10	10	34000169
	12	12	34000170

Subject to change.